



JOHN INFRA

Building Concrete Future

Self Loading Concrete Batching Vehicle



**“WE CREATE THE FUTURE,
BUILDING ON THE PAST AND OUTSHINING THE PRESENT.”**

JOHN GROUP

Our Rich Heritage

Wisent Infratech LLP is a part of the John Energy family and inculcate the same values into its culture. We are pioneers in water well rig manufacturing in India and have been a leading supplier since 30 years. We are a global Brand in Oil and Gas industry with operations spread all over the world.

Customer First Policy

John Family takes immense pride in providing best service in the industry to its customers. After Sales Service & Customer satisfaction is Highest Rated as Company put forth the needs of customers as our utmost priority.

SELF - LOADING CONCRETE BATCHING VEHICLE

Reinforcing mobility:

Traditional concrete batching plants lacks mobility and requires efforts to install and operate. With **JOHN 2.2 CM**, we offer a smooth amalgamation of mobility and efficacy. With its 4x4 wheel drive, this machine can work across any difficult terrain.

Cutting edge technology

We utilize only the very best of components to create our products. Our Units have been designed to deliver stability and efficacy at its very best to your construction needs. The batch can be prepared by only one operator, continuously monitored with weight and volume sensors. It is built at par with global industry standards and thus offer a sturdy built along with ease of operation.

Features :



Water Pump and Imported Fittings

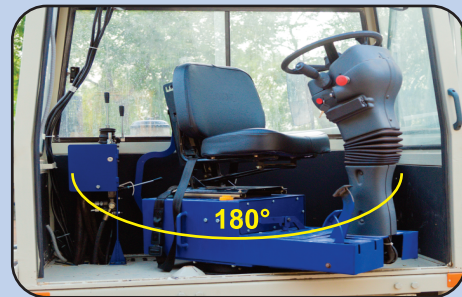

Imported steering column minimizing electrical problems with 180° revolving operator seat

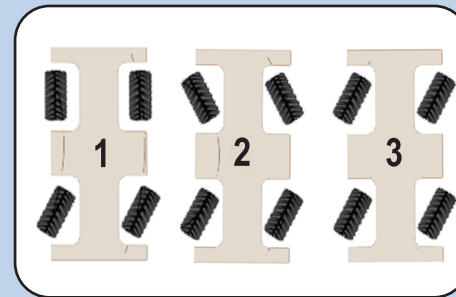

3 way Steering Position System



Weighing Unit with Printer Real time tracking & monitoring system

JOHN 2.2 CM

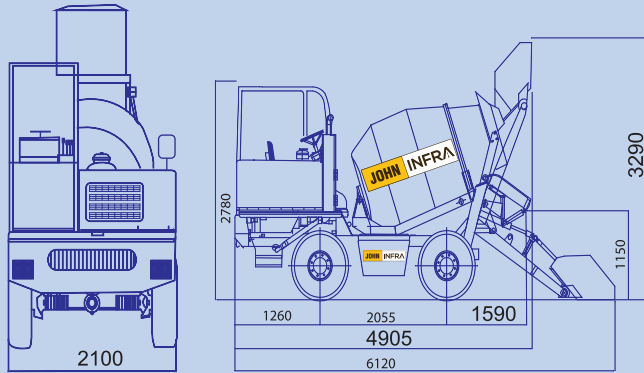

JOHN 4.3 CM

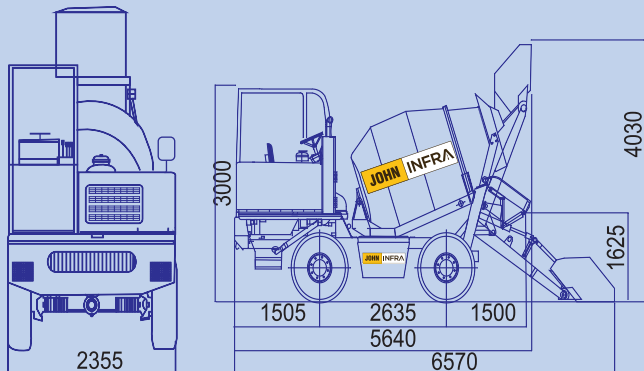

TECHNICAL SPECIFICATION

MODEL	JOHN 2.2 CM	JOHN 4.3 CM
ENGINE	Kirloskar 49 HP Engine	Kirloskar 110 HP Engine
WATER TANK	450 ltr	750 ltr
FUEL TANK	65 ltr	120 ltr
HYDRAULIC TANK	115 ltr	115 ltr
WATER PUMP CAPACITY	230 ltr	230 ltr
BUCKET CAPACITY	350 ltr	585 ltr
DRUM CAPACITY	3.0 cu.m	6.0 cu.m
DRUM OUTPUT	2.2 cu.m	4.3 cu.m
MAX DRUM ROTATION SPEED	19 rpm	20 rpm
NET WEIGHT	5385 kg	7950 kg
GROSS WEIGHT	10085 kg	17550 kg
GRADEABILITY	28°	28°
MAX. VEHICLE SPEED	23 kmph	28 kmph
BRAKING SYSTEM	Wet discs available in front and rear axles	Wet discs available in front and rear axles
DRIVE	4 wheel drive	4 wheel drive
TYRE	12.0/75 -18-12 PR	16.0/70-20-14 PR



Easily Availability of Spare Sparts



Quick Service & Priority Customer Support



Minimum Turning Radius



Maintenance Free & User Friendly Equipped with Parts & User Manual.

JOHN INFRA

Building Concrete Future



Wisent Infratech LLP
Block No 97, Bhupendra Crane,
At. Ditsan, Ta. Mehsana -382732 Gujarat



+91 99251 71496, +91 97262 74774



sales@johninfra.com



www.johninfra.com

